

P-Channel Enhancement Mode MOSFET

Features

- 20V/-2.5A,
 $R_{DS(ON)} = 85m\Omega$ (typ.) @ $V_{GS} = -4.5V$
 $R_{DS(ON)} = 110m\Omega$ (typ.) @ $V_{GS} = -2.5V$
- Super High Dense Cell Design
- Reliable and Rugged

Pin Description

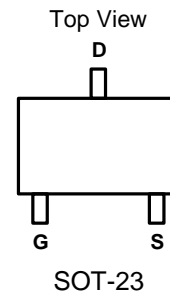

Applications

- Power Management in Notebook Computer, Portable Equipment and Battery Powered Systems.

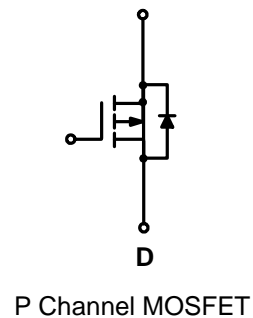

Ordering and Marking Information

<p>MP2301 □□ - □□□</p> <p>Lead Free Code</p> <p>Handing Code</p> <p>Temp. Range</p> <p>Package Code</p>	<p>Package Code A : SOT-23</p> <p>Operating Junction Temp. Range C : -55 to 150°C</p> <p>Handing Code TU : Tube TR : Tape & Reel</p> <p>Lead Free Code L : Lead Free Device Blank : Original Device</p>
<p>MP2301 A: A01X</p>	<p>XXXXX – Date Code</p>

Absolute Maximum Ratings ($T_A=25^\circ\text{C}$ Unless Otherwise Noted)

Symbol	Parameter	Rating	Unit	
V_{DSS}	Drain-Source Voltage	-20	V	
V_{GSS}	Gate-Source Voltage	± 12		
I_D^*	Continue Drain Current	-2.5	A	
I_{DM}^*	Pulsed Drain Current	-10		
I_S^*	Diode continuous forward current	-1.5	A	
T_J	Maximum Junction Temperature	150	$^\circ\text{C}$	
T_{STG}	Storage Temperature Range	-55 to 150		
P_D^*	Maximum Power Dissipation	$T_A=25^\circ\text{C}$	0.83	W
		$T_A=100^\circ\text{C}$	0.3	
$R_{\theta JA}^*$	Thermal Resistance-Junction to Ambient	150	$^\circ\text{C}/\text{W}$	

Notes :

*Surface Mounted on 1in^2 pad area, $t \leq 10\text{sec}$.

Electrical Characteristics ($T_A=25^\circ\text{C}$ Unless Otherwise Noted)

Symbol	Parameter	Test Condition	MP2301A			Unit
			Min.	Typ.	Max.	
Static Characteristics						
BV_{DSS}	Drain-Source Breakdown Voltage	$V_{GS}=0\text{V}, I_{DS}=-250\mu\text{A}$	-20			V
I_{DSS}	Zero Gate Voltage Drain Current	$V_{DS}=-16\text{V}, V_{GS}=0\text{V}$ $T_J=85^\circ\text{C}$			-1	μA
					-30	
$V_{GS(th)}$	Gate Threshold Voltage	$V_{DS}=V_{GS}, I_{DS}=-250\mu\text{A}$	-0.45	-0.7	-1	V
I_{GSS}	Gate Leakage Current	$V_{GS}=\pm 12\text{V}, V_{DS}=0\text{V}$			± 100	nA
$R_{DS(ON)}$	Drain-Source On-state Resistance	$V_{GS}=-4.5\text{V}, I_{DS}=-2.5\text{A}$		85	130	m Ω
		$V_{GS}=-2.5\text{V}, I_{DS}=-2\text{A}$		110	190	
V_{SD}	Diode Forward Voltage	$I_{SD}=-0.5\text{A}, V_{GS}=0\text{V}$		-0.8	-1.3	V
Gate Charge Characteristics^b						
Q_g	Total Gate Charge	$V_{DS}=-10\text{V}, V_{GS}=-4.5\text{V},$ $I_{DS}=-2.5\text{A}$		5	7	nC
Q_{gs}	Gate-Source Charge			0.7		
Q_{gd}	Gate-Drain Charge			0.6		

Electrical Characteristics (Cont.) ($T_A=25^\circ\text{C}$ Unless Otherwise Noted)

Symbol	Parameter	Test Condition	MP2301A			Unit
			Min.	Typ.	Max.	
Dynamic Characteristics^b						
R_G	Gate Resistance	$V_{GS}=0V, V_{DS}=0V, F=1\text{MHz}$		9.2		Ω
C_{iss}	Input Capacitance	$V_{GS}=0V,$ $V_{DS}=-15V,$ Frequency=1.0MHz		360		pF
C_{oss}	Output Capacitance			80		
C_{rss}	Reverse Transfer Capacitance			50		
$t_{d(ON)}$	Turn-on Delay Time	$V_{DD}=-10V, R_L=10\Omega$ $I_{DS}=-1A, V_{GEN}=-4.5V,$ $R_G=6\Omega$		8	16	ns
T_r	Turn-on Rise Time			7	15	
$t_{d(OFF)}$	Turn-off Delay Time			18	35	
T_f	Turn-off Fall Time			8	15	

Notes :

a : Pulse test ; pulse width $\leq 300\mu\text{s}$, duty cycle $\leq 2\%$.

b : Guaranteed by design, not subject to production testing.

Typical Characteristics

Output Characteristics

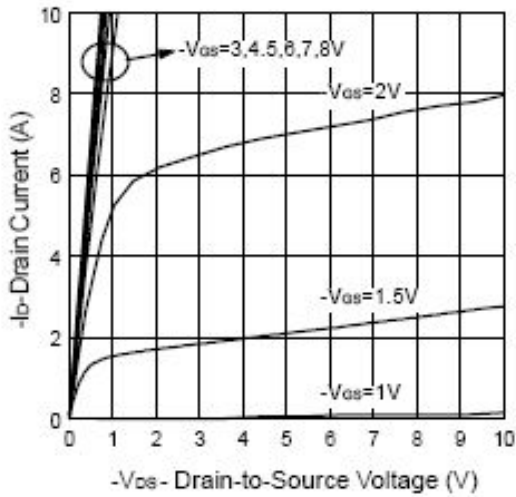

Transfer Characteristics

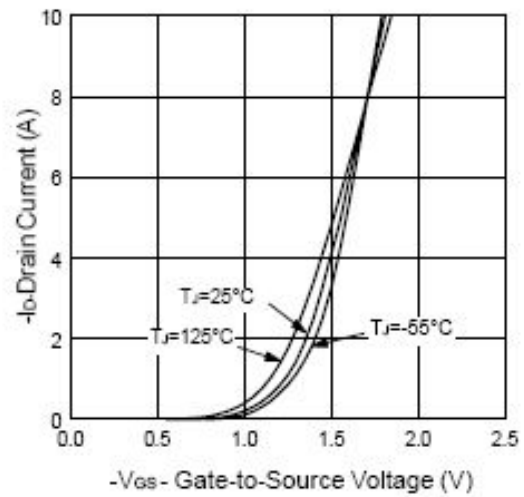

Threshold Voltage vs. Junction Temperature

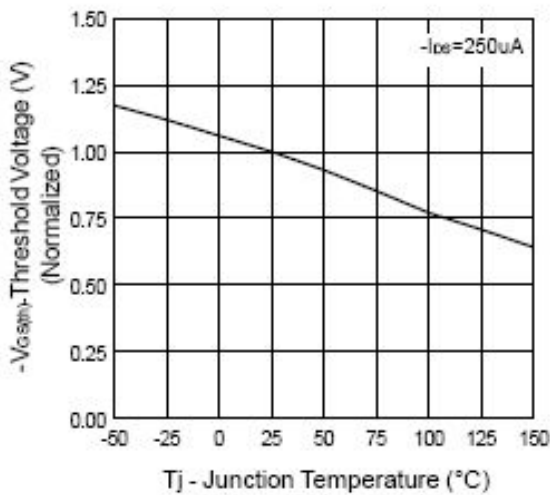

On-Resistance vs. Drain Current

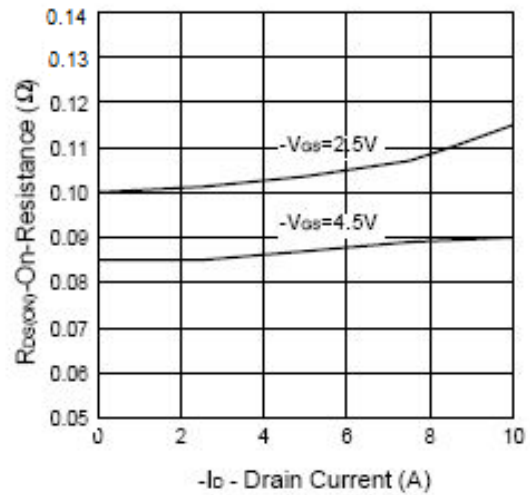

Typical Characteristics

Drain-Source On Resistance

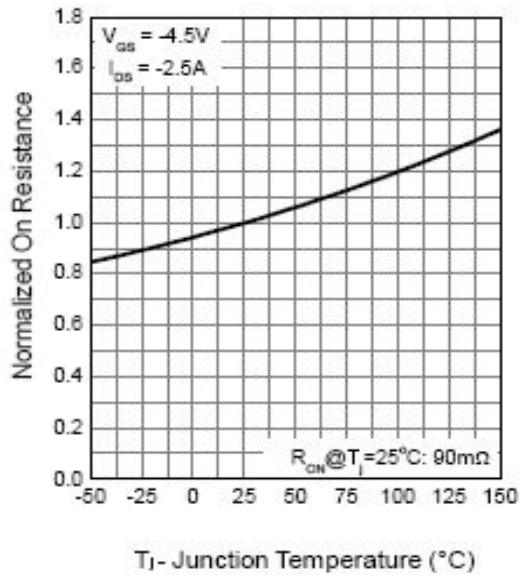

Source-Drain Diode Forward

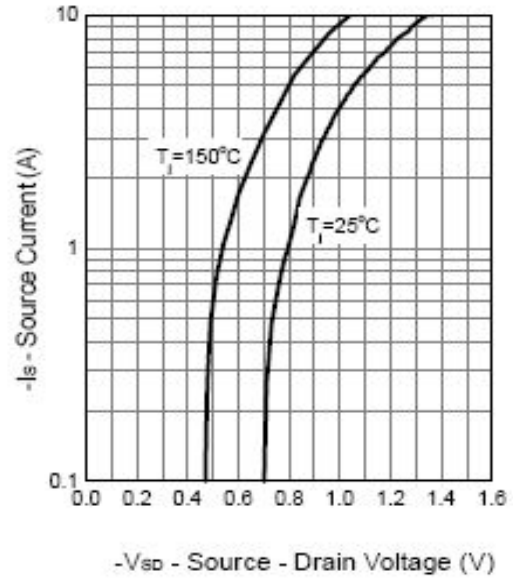

Capacitance

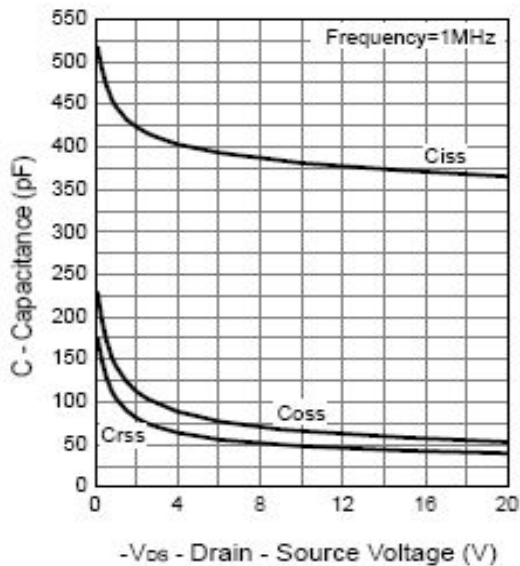

Gate Charge

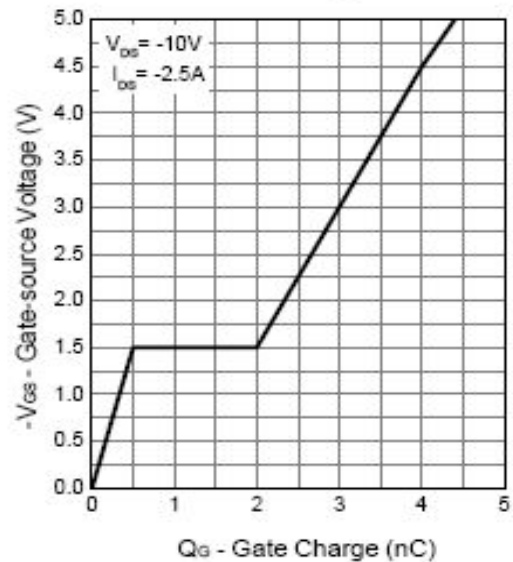

Typical Characteristics

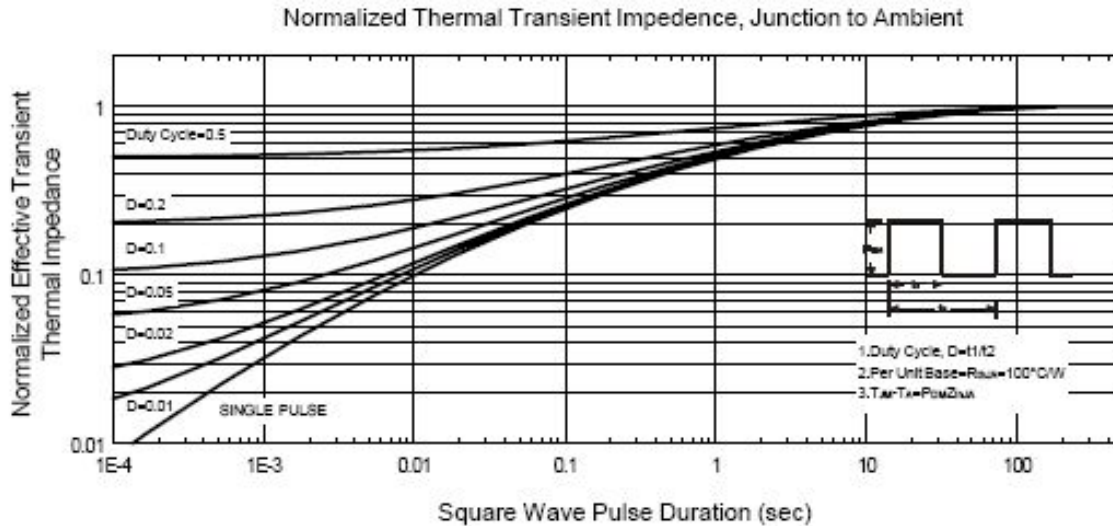
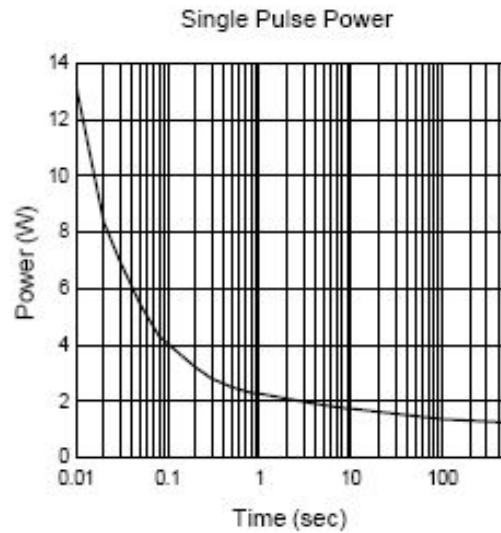
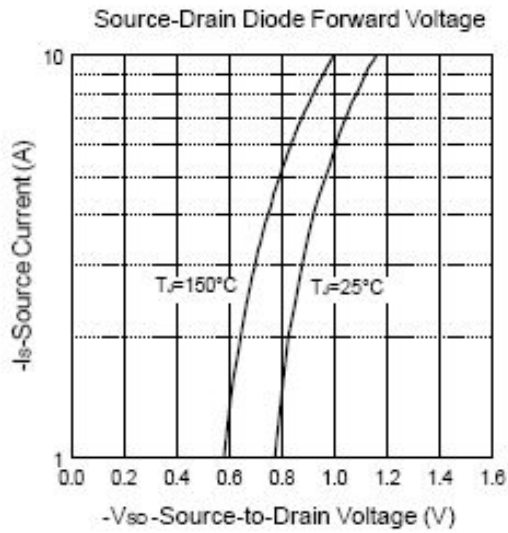

Package Information

SOT-23

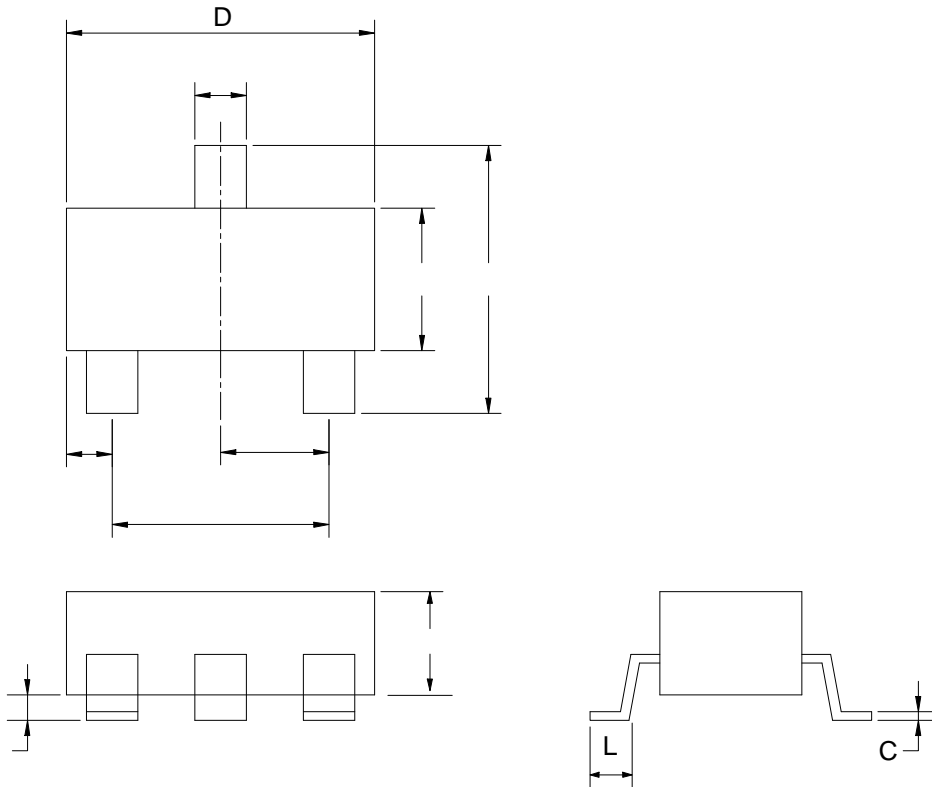

Dim	Millimeters		Inches	
	Min.	Max.	Min.	Max.
A	1.00	1.30	0.039	0.051
A1	0.00	0.10	0.000	0.004
B	0.35	0.51	0.014	0.020
C	0.10	0.25	0.004	0.010
E	1.40	1.80	0.055	0.071
e1	1.90 TYP		0.075 TYP.	
H	2.40	3.00	0.094	0.118
L	0.37		0.015	

Physical Specifications

Terminal Material	Solder-Plated Copper (Solder Material : 90/10 or 63/37 SnPb,100%Sn).
Lead Solderability	Meets EIA Specification RSI86-91, ANSI/J-STD-002 Category 3.

Reflow Condition

(IR/Convection or VPR Reflow)

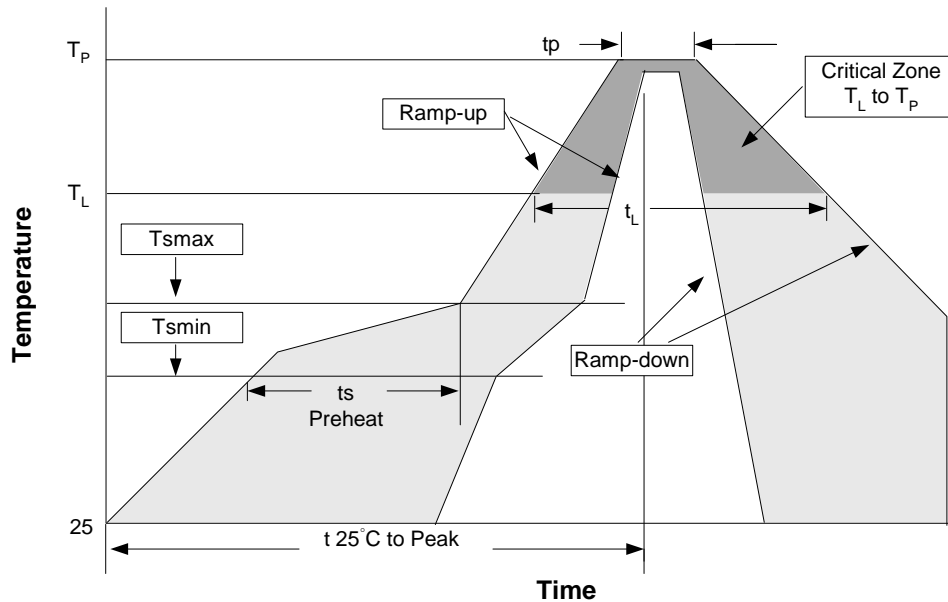

Classification Reflow Profiles

Profile Feature	Sn-Pb Eutectic Assembly		Pb-Free Assembly	
	Large Body	Small Body	Large Body	Small Body
Average ramp-up rate (T_L to T_P)	3°C/second max.		3°C/second max.	
Preheat	100°C		150°C	
- Temperature Min (T_{smin})	150°C		200°C	
- Temperature Max (T_{smax})	60-120 seconds		60-180 seconds	
- Time (min to max) (t_s)				
T_{smax} to T_L			3°C/second max	
- Ramp-up Rate				
Time maintained above:	183°C		217°C	
- Temperature (T_L)	60-150 seconds		60-150 seconds	
- Time (t_L)				
Peak Temperature (T_p)	225 +0/-5°C	240 +0/-5°C	245 +0/-5°C	250 +0/-5°C
Time within 5°C of actual Peak Temperature (t_p)	10-30 seconds	10-30 seconds	10-30 seconds	20-40 seconds
Ramp-down Rate	6°C/second max.		6°C/second max.	
Time 25°C to Peak Temperature	6 minutes max.		8 minutes max.	

Notes: All temperatures refer to topside of the package .Measured on the body surface.

Package Reflow Conditions

pkg. thickness $\geq 2.5\text{mm}$ and all bags	pkg. thickness $< 2.5\text{mm}$ and pkg. volume $\geq 350\text{mm}^3$	pkg. thickness $< 2.5\text{mm}$ and pkg. volume $< 350\text{mm}^3$
Convection 220 $\pm 5/0^\circ\text{C}$		Convection 235 $\pm 5/0^\circ\text{C}$
VPR 215-219 $^\circ\text{C}$		VPR 235 $\pm 5/0^\circ\text{C}$
IR/Convection 220 $\pm 5/0^\circ\text{C}$		IR/Convection 220 $\pm 5/0^\circ\text{C}$

Reliability test program

Test Item	Method	Description
SOLDERABILITY	MIL-STD-883D-2003	245 $^\circ\text{C}$, 5 SEC
HOLT	MIL-STD 883D-1005.7	1000 Hrs Bias @ 125 $^\circ\text{C}$
PCT	JESD-22-B, A102	168 Hrs, 100% RH, 121 $^\circ\text{C}$
TST	MIL-STD 883D-1011.9	-65 $^\circ\text{C}$ ~ 150 $^\circ\text{C}$, 200 Cycles

Carrier Tape & Reel Dimensions

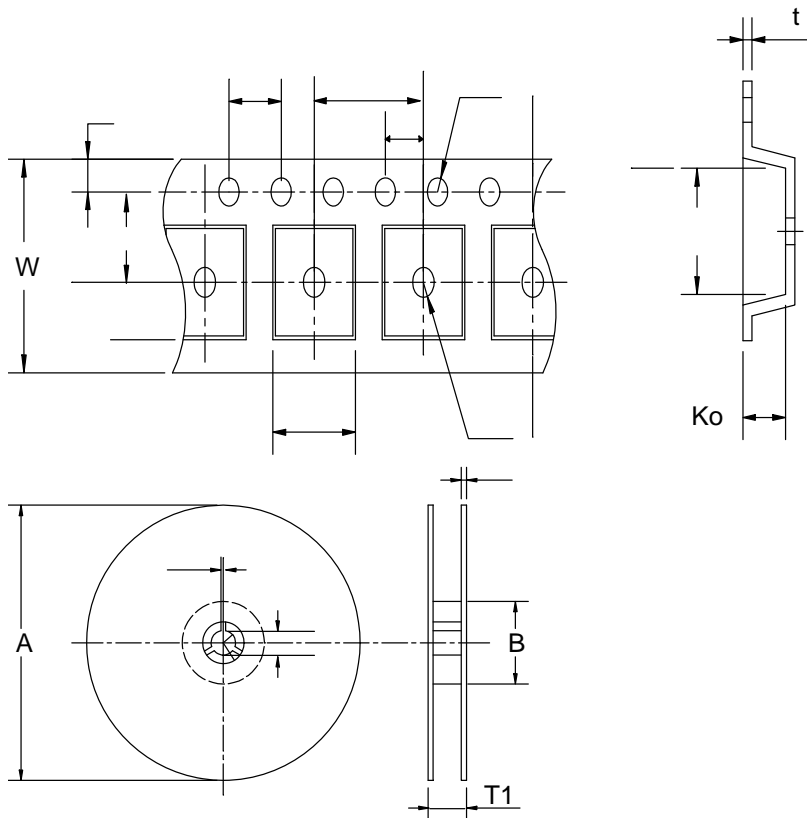



Application	A	B	C	J	T1	T2	W	P	E
SOT- 23	178±1	60 ± 1.0	12.0	2.5 ± 0.15	9.0 ± 0.5	1.4	8.0+ 0.3 - 0.3	4.0	1.75
	F	D	D1	Po	P1	Ao	Bo	Ko	t
	3.5 ± 0.05	1.5 +0.1	φ 0.1MIN	4.0	2.0 ± 0.05	3.1	3.0	1.3	0.2±0.03

(mm)

Cover Tape Dimensions

Application	Carrier Width	Cover Tape Width	Devices Per Reel
SOT-23	8	5.3	3000