

COMPLEMENTARY OUTPUT HALL EFFECT LATCH

❖ GENERAL DESCRIPTION

MP41 is a single-digital-output Hall-Effect latch sensor for high temperature operation. The device includes an on-chip Hall voltage generator for magnetic sensing, an amplifier to amplify Hall voltage, a comparator to provide switching hysteresis for noise rejection, and an output driver. An internal bandgap regulator provides a temperature compensated supply voltage for internal circuits and allows a wide operating supply range.

When the magnetic flux density (B) is larger than operate point (Bop), output is switched on (OUT pin is pulled low). The output state is held on until a magnetic flux density reversal falls below Brp. When B is less than Brp, the output is switched off.

The MP41 is available in SIP-3L package.

❖ FEATURES

- Bipolar Hall-Effect latch sensor
- 4.5V to 24V DC operating voltage
- 20mA output sink current
- Board Operating temperature range of -40°C to +125°C
- Green package: SIP-3L

❖ BLOCK DIAGRAM

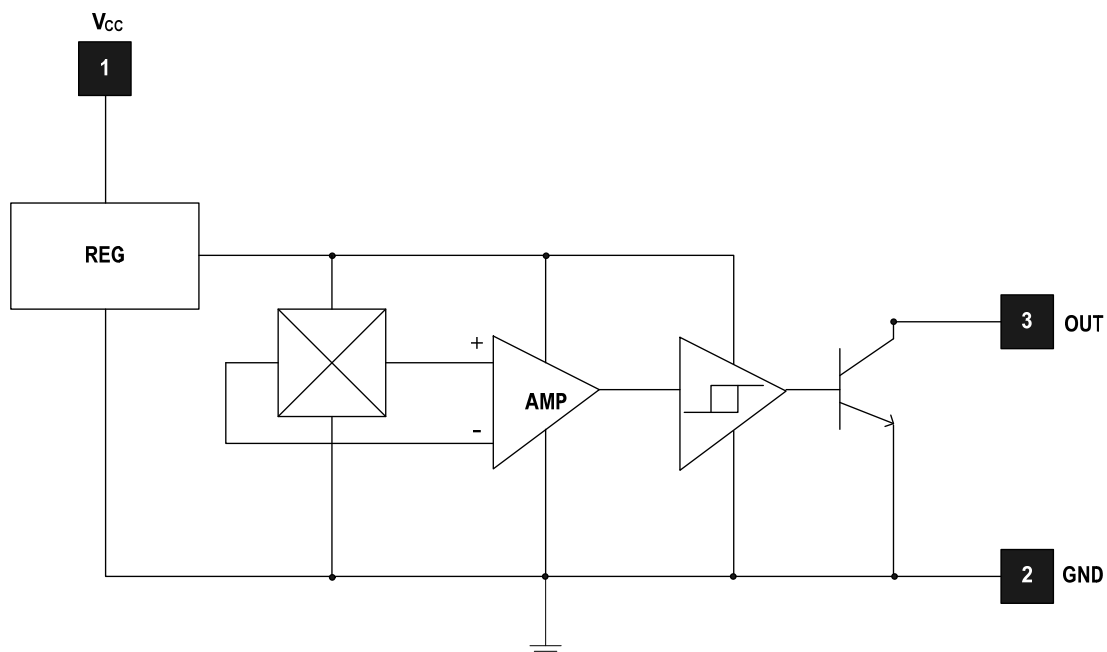

❖ PIN ASSIGNMENT

The package of SW41 is SIP-3L; the pin assignment is given by:

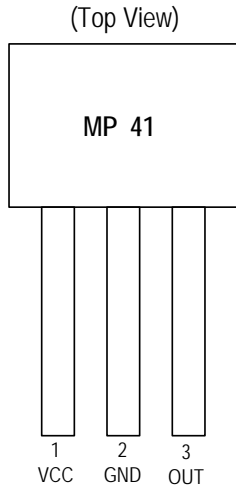

Name	Description
VCC	Positive Power Supply
GND	Ground
OUT	Output Stage

❖ ORDER/MARKING INFORMATION

Order Information	Top Marking
<p>MP41 XX X</p> <p>Package Type: I3: SIP-3L</p> <p>Packing: Blank: Bag, A : Taping</p>	<p>Logo ← MP 41 → Part number</p> <p>YYWWX → ID code:internal</p> <p>WW: 01~52</p> <p>Year: 10=2010, 11=2011</p>

❖ ABSOLUTE MAXIMUM RATINGS (at T_A=25°C)

Characteristics	Symbol	Rating	Unit
Supply Voltage	V _{CC}	60	V
Output Voltage	V _{OUT}	-0.5 to +28	V
Output "On" Current	I _{O (sink)}	25	mA
Storage Temperature Range	T _S	-65 ~ +150	°C
Maximum Junction Temperature	T _J	+150	°C
Package Power Dissipation	P _D	550	mW

❖ ELECTRICAL CHARACTERISTICS

($V_{CC}=12V$, $T_A=25^{\circ}C$, unless otherwise noted)

Characteristics	Symbol	Conditions	Min	Typ	Max	Units
Supply Voltage	V_{CC}	Operating	4.5	-	24	V
Operating Ambient Temperature	T_A	Operating	-40	-	125	$^{\circ}C$
Output Saturation Voltage	$V_{OUT(SAT)}$	$V_{CC} = 12V$, OUT "ON" $I_o = 10mA$	-	300	400	mV
Supply Current	I_{CC}	$V_{CC}=12V$, OUT "OFF"	-	4	8	mA

A grade						
Operation Point	B_{ops} (south pole to brand side)		15	-	65	Gauss
Release Point	B_{rps} (south pole to brand side)		-65	-	-15	Gauss
Hysteresis	$B_{hy}(B_{opx} - B_{rpx})$		-	80	-	Gauss
B grade						
Operation Point	B_{ops} (south pole to brand side)		5	-	80	Gauss
Release Point	B_{rps} (south pole to brand side)		-80	-	-5	Gauss
Hysteresis	$B_{hy}(B_{opx} - B_{rpx})$		-	85	-	Gauss

Note: Magnetic characteristics may vary with supply voltage, operating temperature and after soldering.

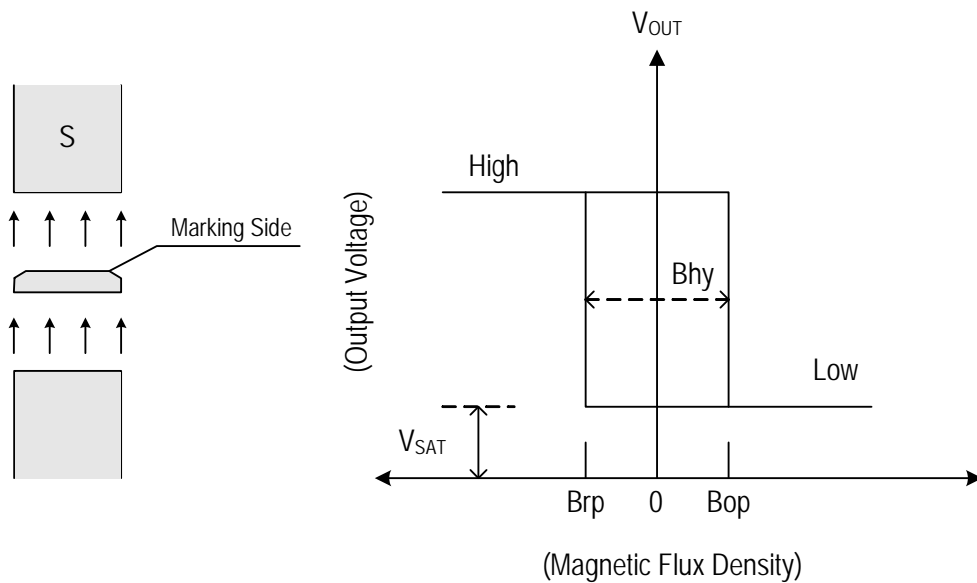

❖ APPLICATION CIRCUIT

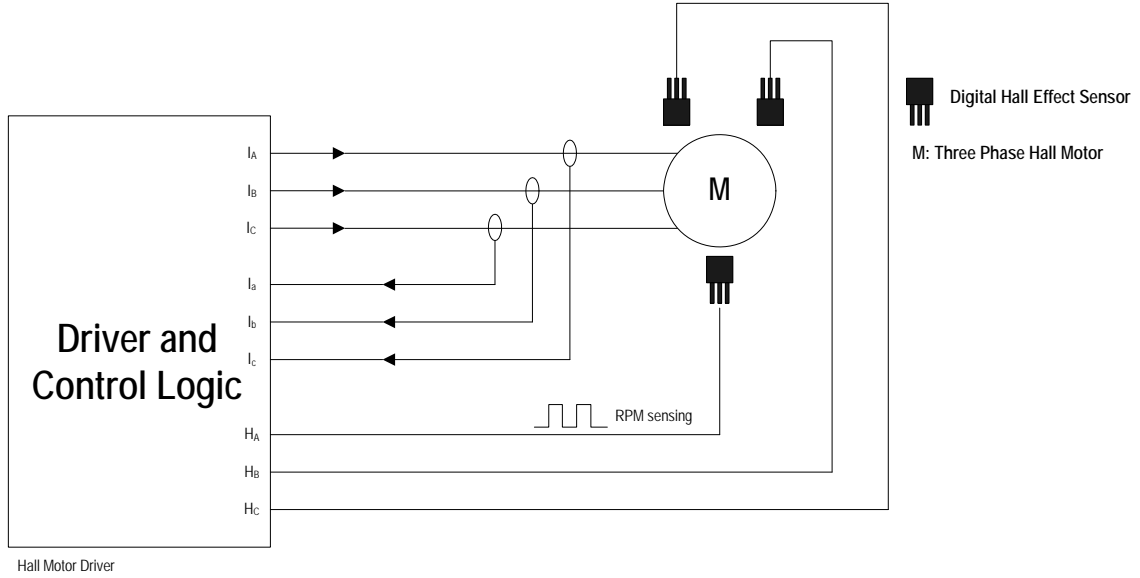

❖ PACKAGE OUTLINES

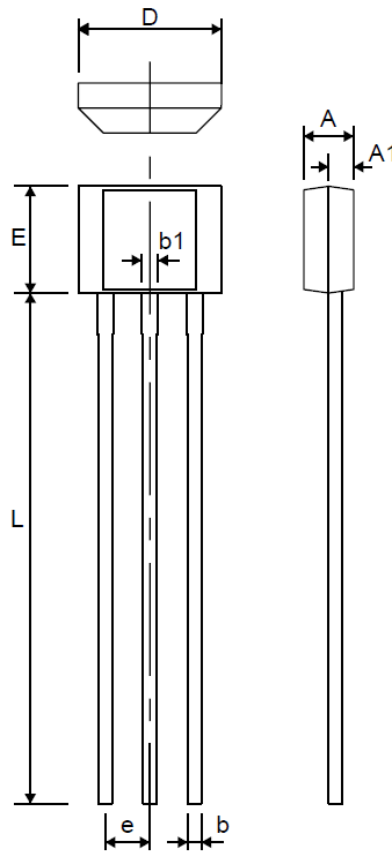

Symbol	Dimensions in Millimeters			Dimensions in Inches		
	Min.	Nom.	Max.	Min.	Nom.	Max.
A	1.20	1.48	1.76	0.047	0.058	0.069
A1	0.75 REF.			0.030 REF.		
b	0.33	0.38	0.43	0.013	0.015	0.017
e1	1.27 BSC			0.050 BSC		
E	2.80	3.00	3.20	0.110	0.118	0.126
L	13.60	14.60	15.60	0.535	0.575	0.614