



Major Power Technology Co.,Ltd.

MP732 High Sensitivity Hall Latch

Revision 1.0

Aug. 2010

1. Overview

Features

- Wide Operating Voltage Range:**
-Single supply voltage 3.5-24V
- Specified Operating Temperature Range:**
-From -40C up to 125C
- High Magnetic Sensitivity**
- Chopper-Stabilized Amplifier Stage**
- Lower Power Consumption**
- Embedded internal 10K pull-up resistor**
- High ESD Capability**
-4KV HBM ESD Capability

Application Examples

- Automotive, Consumer and Industrial**
- Solid-State Switch**
- Brushless DC Motor Commutation**
- Speed Detection**
- Linear Position Detection**
- Angular Position Detection**
- Proximity Detection**

Product Description

The MP732 is a Hall-effect latch designed in mixed-signal CMOS technology. The device integrates a voltage regulator, Hall sensor with dynamic offset cancellation system, Schmitt trigger and an open-drain output driver, all in a single package.

Thanks to its wide operating voltage range and extended choice of temperature range, it is quite suitable for use in automotive, industrial and consumer applications.

The device is delivered in a Small Outline Transistor (SOT) for surface mount process and in a Plastic Single In Line (SIP3-3L) for through hole mount.

Both 3-lead packages are RoHS compliant.

Pin Configuration

Table 1-1: Pin definition and description for SOT-3L

No	Pin	Function
1	VDD	Power
2	OUT	Output
3	GND	Ground

Table 1-2: Pin definition and description for SIP-3L

No	Pin	Function
1	VDD	Power
2	GND	Ground
3	OUT	Output

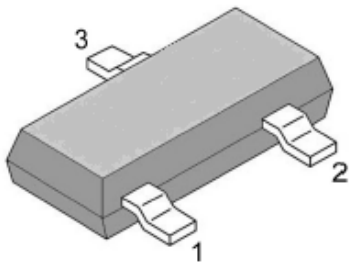

Figure 1-1 SOT23 package

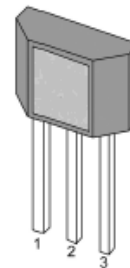

Figure 1-2 SIP-3L flat package

2. General

2.1 Brief Theory of Operation

- The magnetic flux is transferred to voltage signal by the Hall device.
- The Instrument amplifier amplifies the Hall voltage into a large swing signal.
- The dynamic offset cancelation system reduce the offset of Hall device and amplifier
- The hysteresis comparator converts the amplified signal into switch signal as to the setting
- The output stage latches the comparator out, and gives a 10K pull high output

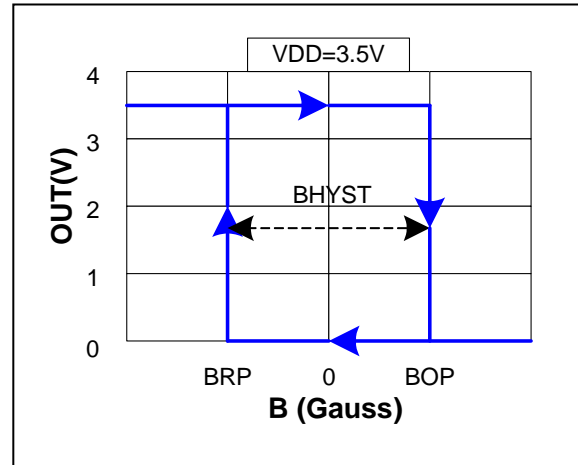

Figure 2-1: Example of Sensor Output

2.2 Transfer Function

Figure 2-1 shows one transfer example of the device.

2.3 Block Diagram

Figure 2-2 shows the simplified block structure.

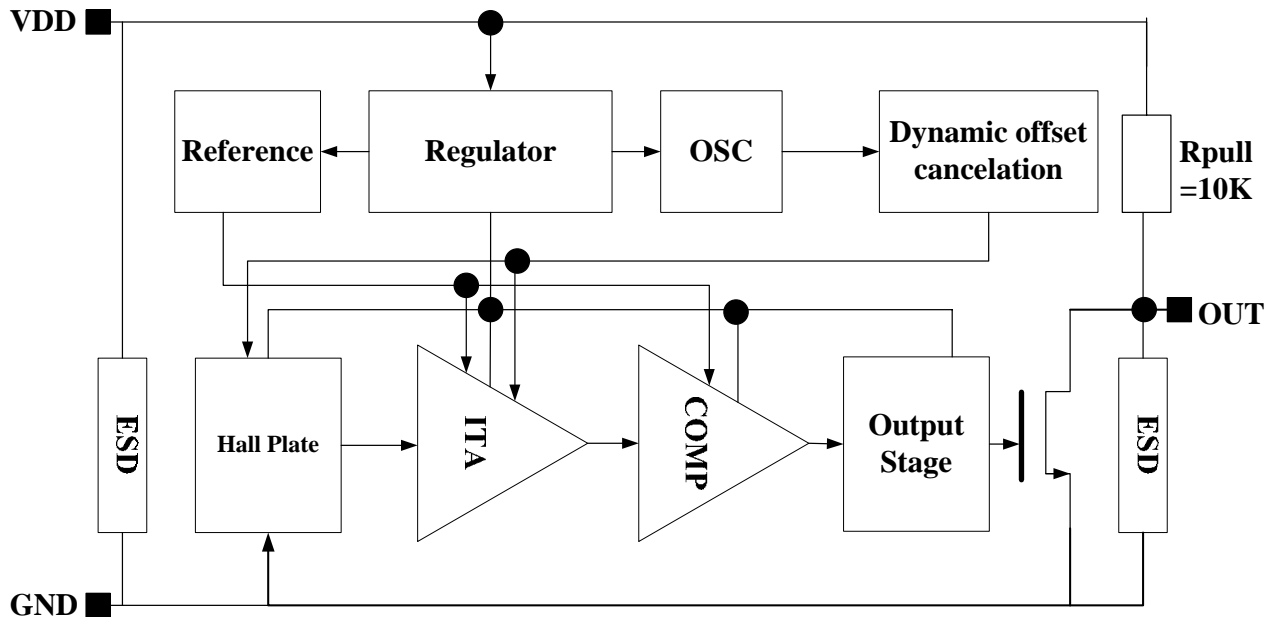

Figure 2-2: Block Diagram

3. Function Description

3.1 Definition of Magnetic Parameters

BOP: Operating Point
Magnetic flux density applied on the branded side of the package which turns the output driver ON ($V_{OUT} = V_{DSon}$)

BRP: Release Point
Magnetic flux density applied on the branded side of the package which turns the output driver OFF ($V_{OUT} = \text{high}$)

BHYST: Hysteresis Window
BOP-BRP

3.2 Definition of Switching Function

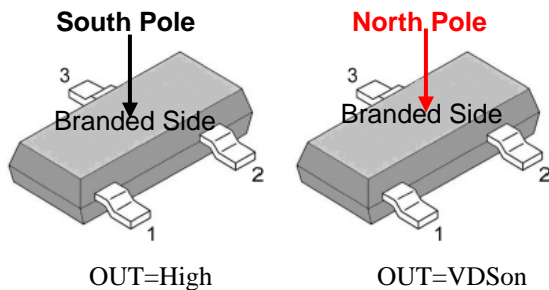

Figure 3-1: Switching Point of SOT23

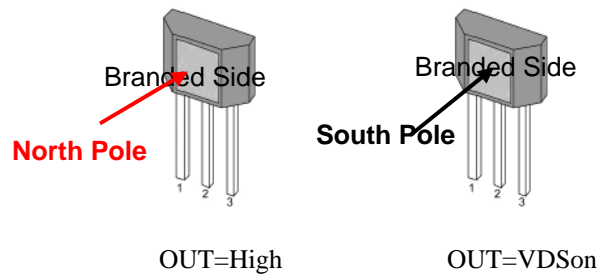

Figure 3-2: Switching Point of SIP-3L

DC Operating Parameters $T_A = -40C$ to $125C$, $V_{DD} = 3.5V$ to $24V$ (unless otherwise specified)

Table 3-1: Switching Function

Parameter	Pole(SOT23)	OUT(SOT23)	Pole(SIP-3L)	OUT(SIP-3L)
South Pole	$B < BRP$	High	$B > BOP$	V_{DSon}
North Pole	$B > BOP$	V_{DSon}	$B < BRP$	High

3.3 Latch Characteristic

The device exhibits latch magnetic switching characteristics. Therefore, it requires both south and north poles to operate properly.

The device behaves as a latch with symmetric operating and release switching points ($B_{OP} = |B_{RP}|$). This means magnetic fields with equivalent strength and opposite direction drive the output high and low. Removing the magnetic field ($B \rightarrow 0$) keeps the output in its previous state. This latching property defines the device as a magnetic memory.

A magnetic hysteresis B_{HYST} keeps B_{OP} and B_{RP} separated by a minimal value. This hysteresis prevents output oscillation near the switching point.

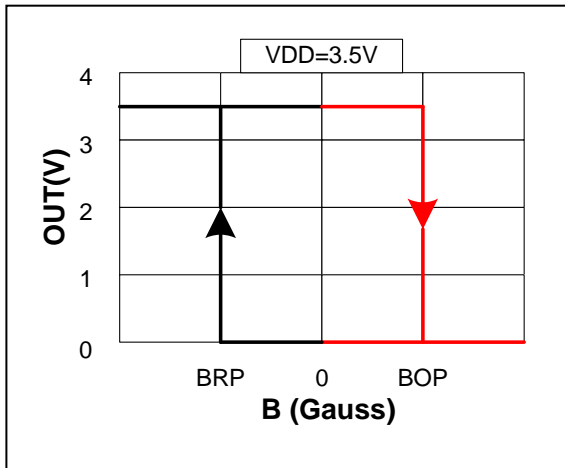

Figure 3-3: Latch Characteristic
SOT23 Package

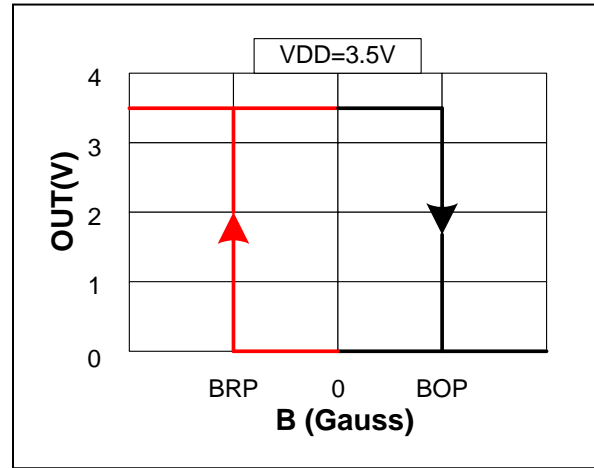

Figure 3-4: Latch Characteristic
SIP-3L Package

Note:

- South Pole
- North Pole

4. Electrical and Magnetic Characteristics

4.1 Absolute Maximum Ratings

Absolute maximum ratings are limiting values to be applied individually, and beyond which the serviceability of the circuit may be impaired. Functional operability is not necessarily implied. Exposure to absolute maximum rating conditions for an extended period of time may affect device reliability.

Table 4-1: Absolute maximum ratings: all voltages listed are referenced to GND

Symbol	Parameters	Min	MAX	Unit	Notes
Ts	Storage temperature	-50	150	C	
TJ	Junction temperature	-50	150	C	
VDD	Supply voltage		28	V	
IDD	Supply current		50	mA	
VOUT	Output voltage		28	V	
IOUT	Continuous output current		50	mA	

4.2 Electrical Characteristics

Table 4-2: Characteristics: at Ta=-40C to +125C, VDD=3.5 to 24V, if not otherwise specified.

Parameter	Symbol	Test Condition	Min	Typ	Max	Units
Supply Voltage	VDD	Operating	3.5		24	V
Supply Current	IDD1	B < BRP			5	mA
Supply Current	IDD2	B > BOP, No resistance loading at OUT			7	mA
Output Saturation Voltage	VDSON	IOUT = 20mA, B > BOP			0.5	V
Output Leakage Current	I _{OFF}	B < BRP, VOUT=24V			10	uA
Output Rise Time	TR	RL=1KOhm, CL=20pF			0.45	uS
Output Fall Time	TF	RL=1KOhm, CL=20pF			0.45	uS
Rpull resistance at OUT	Rpull		7	10	13	KOhm
Maximum Switching Frequency	F _{SW}			10		KHz
Package Thermal Resistance	R _{TH}	Single layer (1S) Jedec board		301		° C/W
Magnetic Operating Point	BOP		0.5		7.5	mT
Magnetic Release Point	BRP		-7.5		-0.5	mT
Hysteresis Window	B _{HYST}		5.6	8	10.4	mT
Electro-Static Discharge	ESD	HBM		4		KV

Note: For detail SPEC or specific requirement, please contact us

4.3 Typical Characteristics

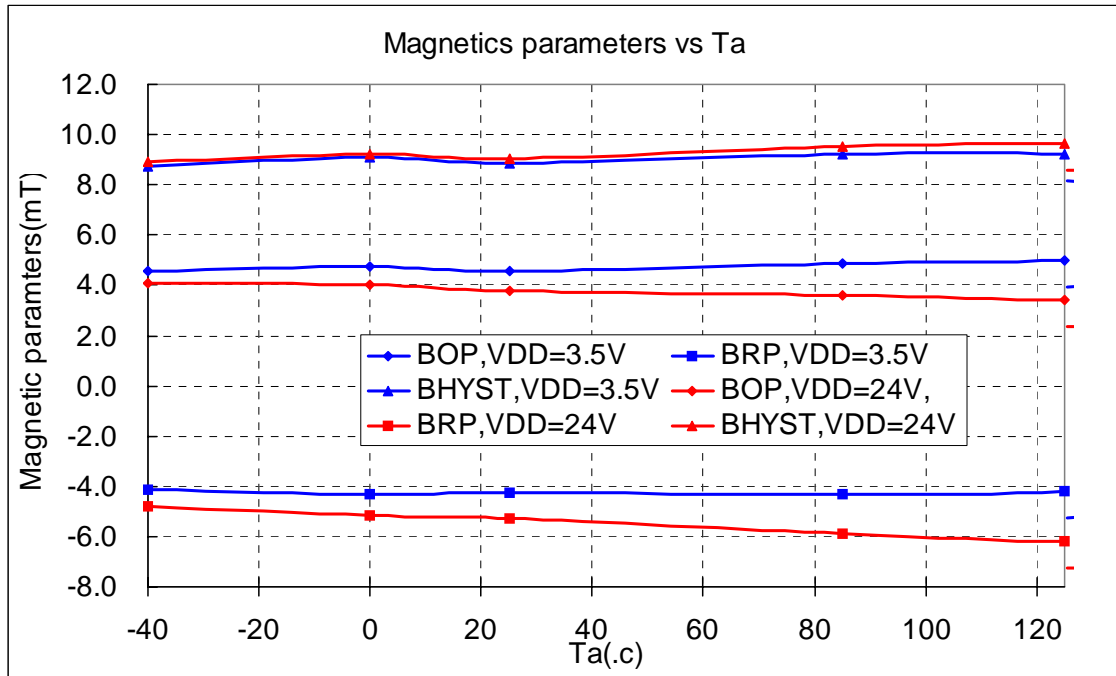

Figure 4-1: Magnetic parameters VS Ta

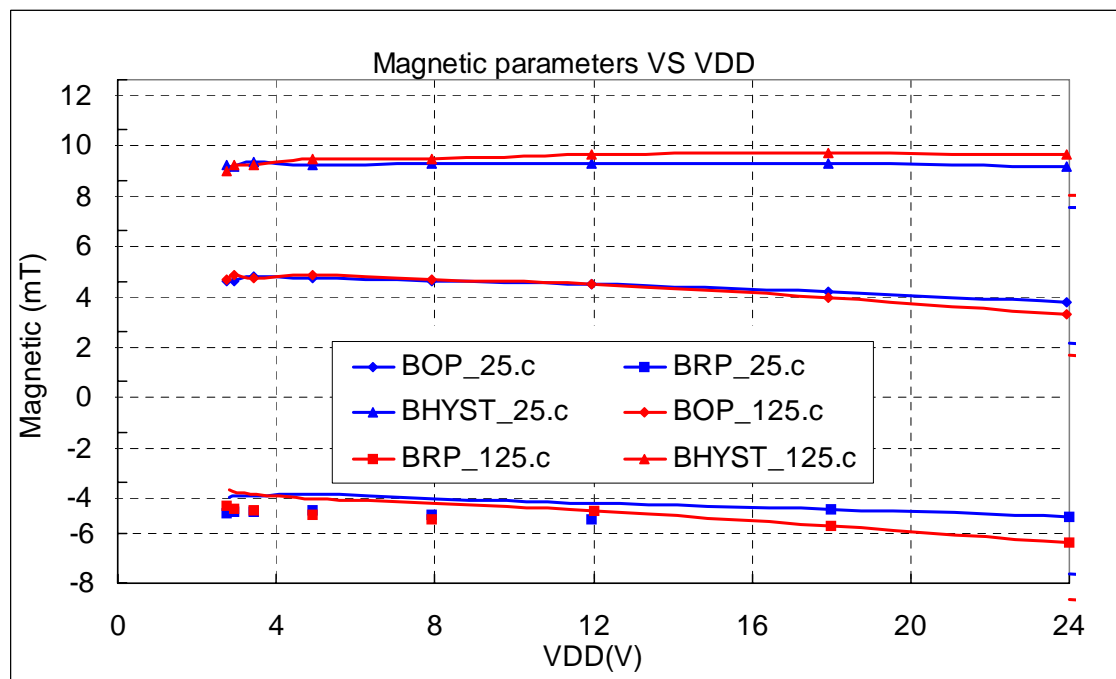

Figure 4-2: Magnetic parameters VS VDD

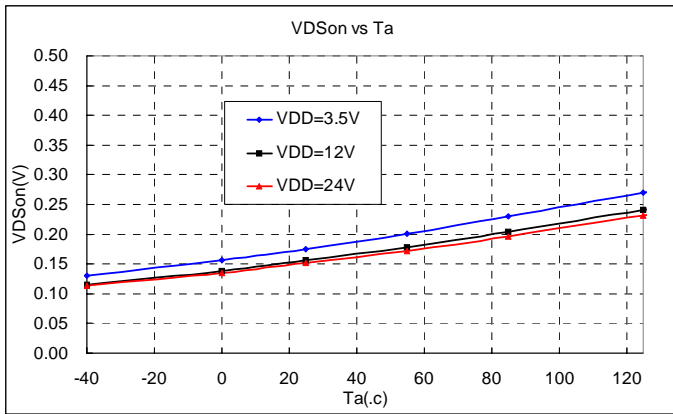

Figure 4-3: VDSon VS Ta

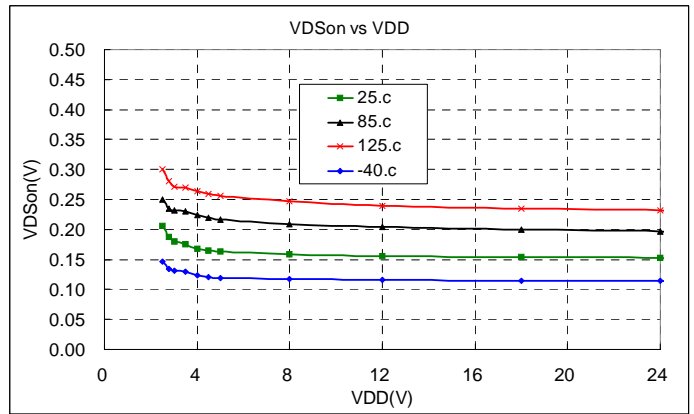

Figure 4-4: VDSon VS VDD

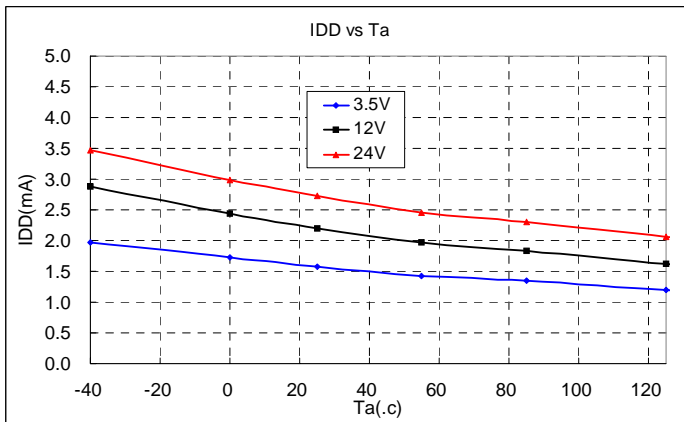

Figure 4-5: IDD VS Ta

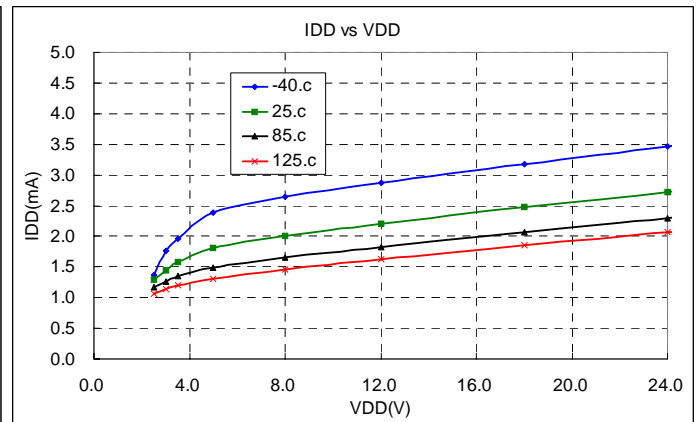

Figure 4-6: IDD VS VDD

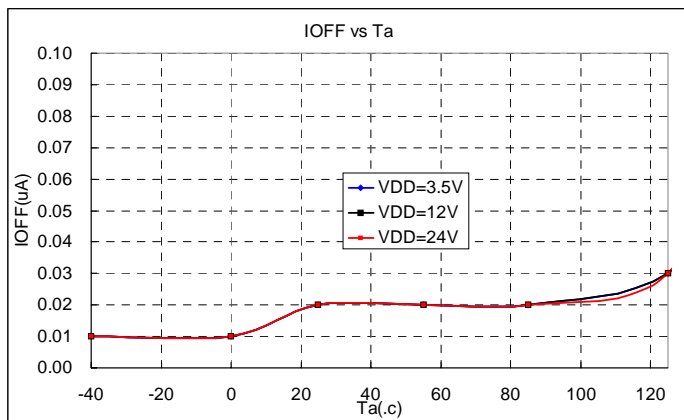

Figure 4-7: IOFF VS Ta

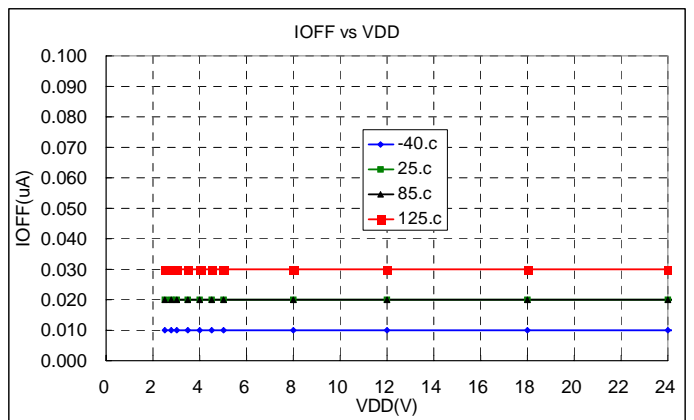
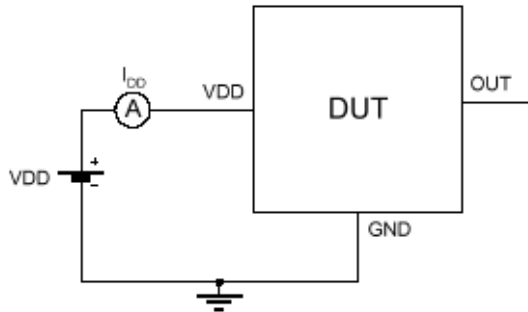

Figure 4-8: IOFF VS VDD

4.4 Test Conditions

Note: DUT= Device Under Test

Supply Current



Note1- The supply current I_{DD} represents the static supply current. Out is left open when measurement
 Note2- The device is put under magnetic field with $B < BRP$

Figure 4-9: I_{DD} Test Condition

Output Saturation Voltage

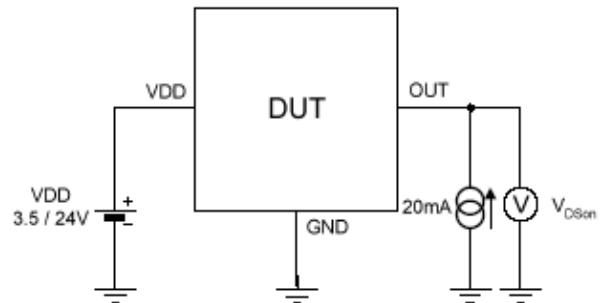

Note1- The output saturation voltage V_{DSon} is measured at $V_{dd}=3.5V$ and $V_{Dson}=24V$.
 Note2- The device is put under magnetic field with $B > BOP$

Figure 4-10: V_{DSon} Test Condition

Output Leakage Current

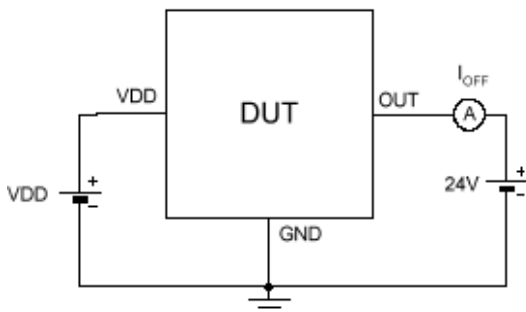

Note1- The device is put under magnetic field with $B < BRP$

Figure 4-11: I_{OFF} Test Condition

Magnetic Thresholds

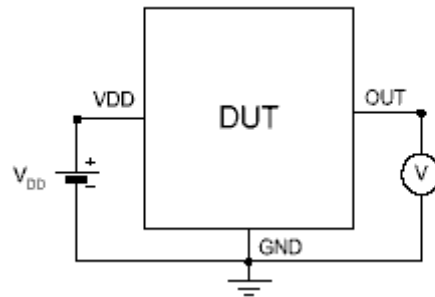

Note1- BOP is determined by putting the device under magnetic field swept from BRP_{min} up to BOP_{max} until the output is switch on
 Note2- BRP is determined by putting the device under magnetic field swept from BOP_{max} down to BRP_{min} until the output is switch off

Figure 4-12: Magnetic parameters Test Condition

5. Application Information

5.1 Typical Three –Wire Application Circuit

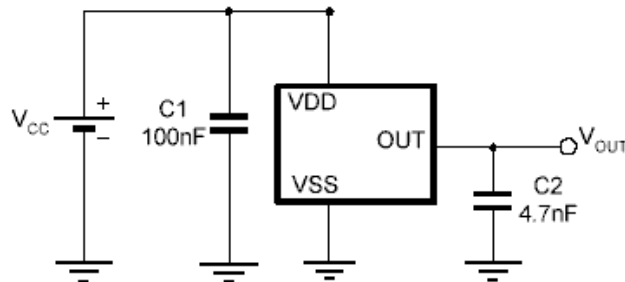
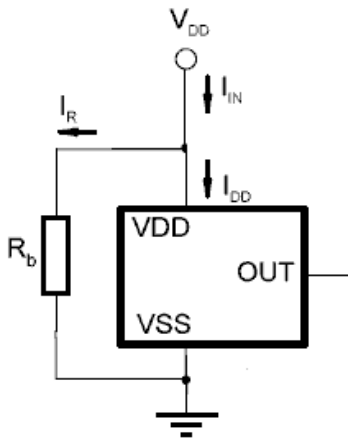

Figure 5-1: 3-Wire Application Circuit

5.2 Two-Wire Application Circuit



Note:

With this circuit, precise ON and OFF currents can be detected using only two connecting wires. The resistors Rpull and Rb can be used to bias the input current. Refer to the part specifications for limiting values.

$$\text{BRP: } I_{\text{OFF}} = I_R + I_{\text{DDOFF}} = V_{\text{DD}}/R_b + I_{\text{DDOFF}}$$

$$\text{BOP: } I_{\text{ON}} = I_R + I_{\text{DDON}} = I_{\text{OFF}} + V_{\text{DD}}/10K$$

Figure 5-2: 2-Wire Application Circuit

5.3 Three-Wire Circuit For Automotive and Harsh, Noisy Application

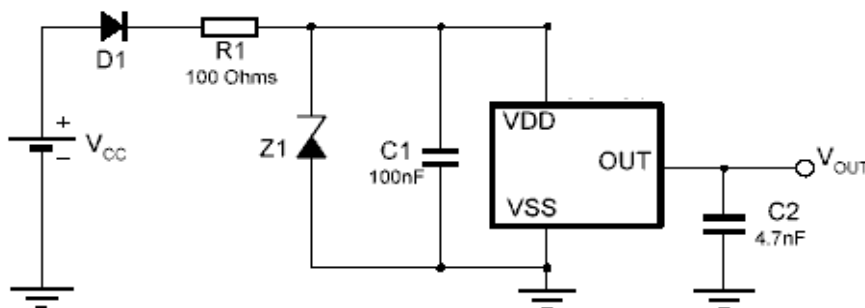

Figure 5-3: 3-Wire Application Circuit For Harsh and Noisy Environment



5.4 Application Comments

5.4.1 For proper operation, a 100nF bypass capacitor should be placed as close as possible to the device between the VDD and ground pin.

5.4.2 For reverse voltage protection, it is recommended to connect a resistor or a diode in series with the VDD pin. When using a resistor, three points are important:

- The resistor has to limit the reverse current to 50mA maximum ($VCC / R1 \leq 50mA$)
- The resulting device supply voltage VDD has to be higher than VDD min ($VDD = VCC - R1 \times IDD$)
- The resistor has to withstand the power dissipated in reverse voltage condition ($PD = VCC^2 / R1$)

When using a diode, a reverse current cannot flow and the voltage drop is almost constant ($\approx 0.7V$). Therefore, a 100W/0.25W resistor for 5V application and a diode for higher supply voltage are recommended. Both solutions provide the required reverse voltage protection.

5.4.3 When a weak power supply is used or when the device is intended to be used in noisy environment, it is recommended that figure 13.3 from the Application Information section is used. The low-pass filter formed by R1 and C1 and the Zener diode Z1 bypass the disturbances or voltage spikes occurring on the device supply voltage VDD. The diode D1 provides additional reverse voltage protection.

6 Ordering information

MP-XXXX-XXXX	
1 2 3 4 5 6 7 8 9 0	
- 1: Prefix	
- 2: Hall Sensor	
- 3: function	1=Latch 2=Switch 4= Linear
- 4: voltage	4=LV 8=HV
- 5: serial number	
- 6: design option	
- 7: package type	SE=SOT23; UA=SIP-3L
- 8: temperature	C= (0~70C) I= (-40~85C) E= (-40~125C)
- 9: pack type	T=Tube R=Tape
- 0: pating technology	Blank= Standard; G= ECOPACK(RoHS compliant)

7. Package Information

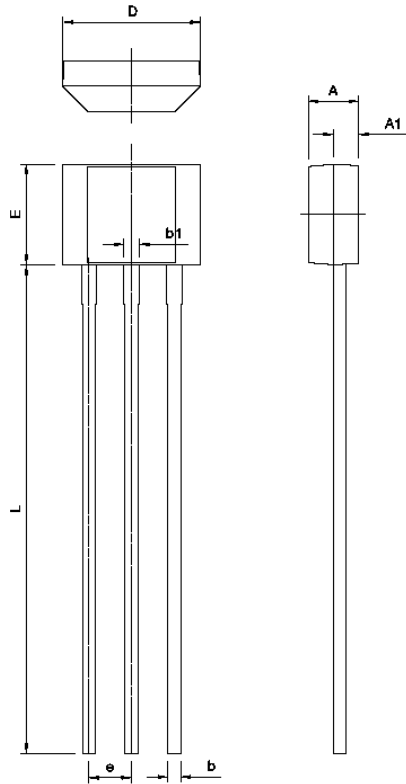

DIMENSIONS

REF.	Millimeter		REF.	Millimeter	
	Min.	Max.		Min.	Max.
A	1.245	1.753	D	3.962	4.216
A1	0.750 REF.		E	2.870	3.124
b	0.330	0.432	L	13.60	15.60
b1	0.406	0.508	e	1.27 REF.	

Fig7-1 Package information of SIP-3L

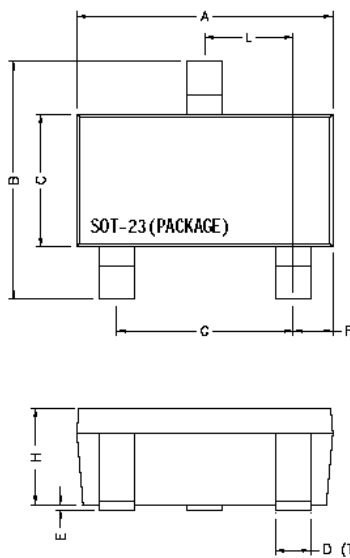

DIMENSIONS

REF.	Millimeter		REF.	Millimeter	
	Min.	Max.		Min.	Max.
A	2.70	3.10	G	2.10 REF.	
B	2.40	2.80	H	1.00	1.30
C	1.40	1.60	I	0.10	0.20
D	0.35	0.50	J	0.40	-
E	0	0.10	L	0.95	1.15
F	0.45	0.55	M	0°	10°
N	0.30	0.60			

Fig7-2 Package information of SOT-23

Product Datasheet Change Notice

Version	Contents	Date
1.0	Datasheet	Aug.,2010